



# Roundell Unit Coolers

## PRODUCT DATA & INSTALLATION

Bulletin K30-R-PDI-14

1064042

We are on the Internet   
[www.keepriterefrigeration.com](http://www.keepriterefrigeration.com)

High Temperature Applications  
 (35 °F and Higher)  
 Air Defrost

Electrical Power: 115/1/60

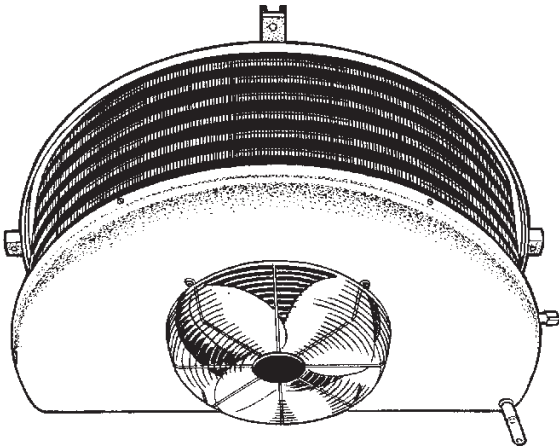

- Direct backwall location and minimum height provides maximum usable storage space.
- Textured heavy gauge aluminum cabinet - lightweight, doesn't show scratches.
- Rigid, slotted channel hangers simplify installation.
- Hinged drain pan for ease of cleaning and service.
- Full collar aluminum plate fins on expanded seamless copper tubes ensure optimum heat transfer efficiency.
- Fan motors are inherently protected

### NOMENCLATURE

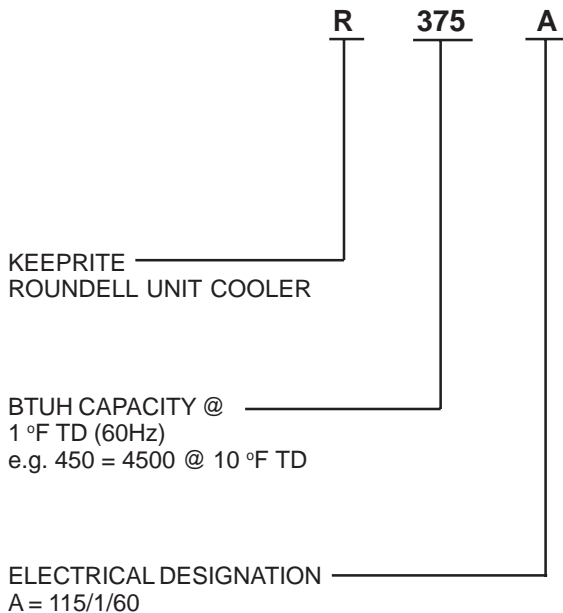

### CONTENTS

### PAGE

Nomenclature.....	Cover
Capacity Data.....	2
Electrical Data.....	2
Typical Field Wiring.....	2
Dimensinal & Physical Data.....	3
Thermostatic Expansion Valve.....	4
Installation Instructions.....	5
Service Parts List.....	6
Service Log.....	6
Warranty.....	7
Project Information.....	7
“As Built” Service Parts.....	Back

# SPECIFICATIONS

## CAPACITY DATA

MODEL No.	CAPACITY (BTUH)			AIR FLOW CFM	REFR'G CHARGE R22* Lbs.
	10°F TD	12°F BTU/HR	15°F BTU/HR		
R 375	3730	4480	5600	770	1.25
R 485	4880	5860	7320	770	1.77
R 595	6050	7260	9080	1280	2.10
R 775	7900	9480	11850	1300	3.02
R 905	8900	10680	13350	1380	3.28
R 1025	10200	12240	15300	2025	3.77
R 1305	12800	15360	19200	2000	4.81
R 2050	20400	24480	30600	4050	7.50

\* R-22 at 30 °F S.S.T. with coil 30% full

## ELECTRICAL DATA

### 115/1/60 (SHADED POLE MOTOR)

MODEL	QTY.	H.P.	RPM	TOTAL F.L.A.	M.C.A.	M.O.P.
R375	1	1/20	1550	1.6	2	15
R485	1	1/20	1550	1.6	2	15
R595	1	1/20	1550	1.6	2	15
R775	1	1/15	1050	2.1	2.63	15
R905	1	1/15	1050	2.1	2.63	15
R1025	1	1/15	1050	2.1	2.63	15
R1305	1	1/15	1050	2.1	2.63	15
R2050	2	1/15	1050	4.2	4.73	15

### 115/1/60 (OPTIONAL P.S.C. MOTOR)

MODEL	QTY.	H.P.	RPM	TOTAL F.L.A.	M.C.A.	M.O.P.
R375	1	1/20	1600	0.6	0.75	15
R485	1	1/20	1600	0.6	0.75	15
R595	1	1/20	1600	0.6	0.75	15
R775	1	1/15	1060	1.32	1.65	15
R905	1	1/15	1060	1.32	1.65	15
R1025	1	1/15	1060	1.32	1.65	15
R1305	1	1/15	1060	1.32	1.65	15
R2050	2	1/15	1060	2.64	2.97	15

M.C.A. = Minimum Circuit Ampacity

M.O.P. = Maximum Overcurrent Protection

## TYPICAL FIELD WIRING

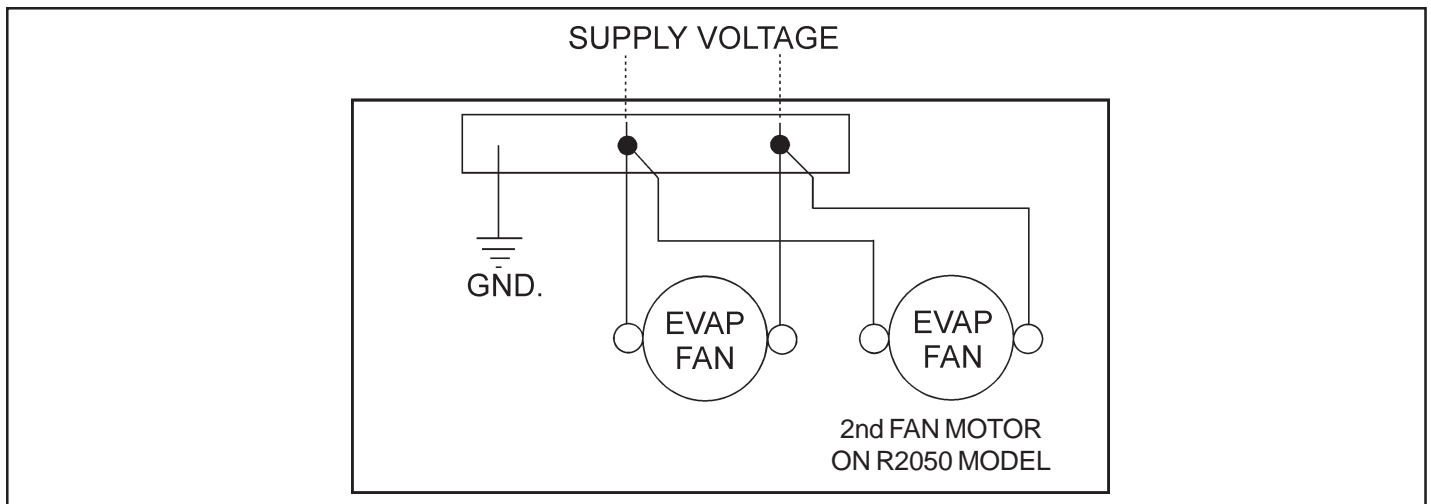

# DIMENSIONAL AND PHYSICAL DATA DATA

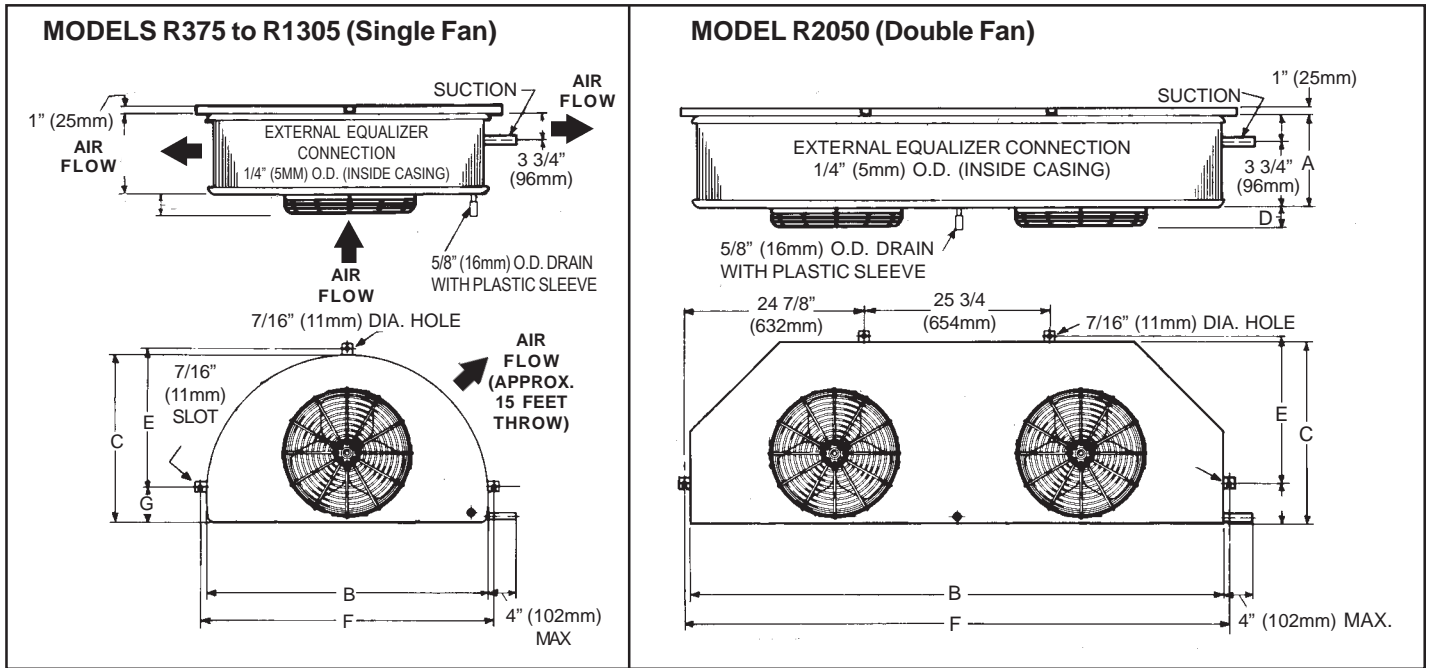

MODEL		A	B	C	D	E	F	G	Suct. Conn. O.D.		Shipping Weight Lbs.	
									in	mm	Lbs.	Kg.
R 375	in	8 1/8	33 1/4	20 3/4	2	16 3/4	34 3/4	4 3/4	5/8	15.9	72	32.7
R 485	mm	(206.4)	(844.6)	(527.0)	(50.8)	(425.5)	(882.7)	(120.7)	5/8	15.9	76	34.5
R 595	in	11 1/8	39 1/4	23 3/4	2 1/4	19 3/8	40 3/4	5 1/8	5/8	15.9	98	44.5
R 775	mm	(282.6)	(997.0)	(603.3)	(57.2)	(492.1)	(1035.0)	(130.2)	7/8	22.2	104	47.2
R 905	in	11 1/8	42 1/4	25 1/4	2 1/2	20 3/8	43 3/4	5 5/8	7/8	22.2	108	49
R 1025	mm	(282.6)	(1073.1)	(641.4)	(63.5)	(417.5)	(1111.3)	(142.9)	7/8	22.2	114	51.2
R 1305	mm	(320.7)	(1073.1)	(641.4)	(63.5)	(417.5)	(1111.3)	(142.9)	7/8	22.2	124	56.2
R 2050	in	12 5/8	74	25 1/4	2 1/2	20 3/8	75 1/2	5 5/8	1 1/8	28.6	187	84.8
	mm	(320.7)	(1879.6)	(641.4)	(63.5)	(417.5)	(1917.5)	(142.9)				

NOTE: 5/8" (15.9 mm) O.D. Drain connection on all models.  
 1/2" (12.7 mm) Flare TX valve connection on all models R375 thru T775  
 1/2" (12.7 mm) Sweat TX Valve connection on models R905 thru R2050.

# THERMOSTATIC EXPANSION VALVE SELECTION CHART FOR +35°F ROOMS AND UP

AIR DEFROST			SPORLAN VALVE MODEL			ALCO VALVE MODEL		
MODEL	TD °F	CAPACITY BTUH	REFRIGERANT R22	REFRIGERANT R502/404A/507	REFRIGERANT R12/R134a	REFRIGERANT R22	REFRIGERANT R502/404A/507	REFRIGERANT R134a
R375	10	3,730	EGVE-1/3-C	EGSE-1/4-SE	EGJE-1/6-JC	HFES-1/4-HC	HFES-1/4-SC	HFES-1/2-MC
	12	4,480	EGVE-1/3-C	EGSE-1/2-SE	EGJE-1/4-JC	HFES-1/2-HC	HFES-1/4-SC	HFES-1/2-MC
	15	5,600	EGVE-1/2-VC	EGSE-1/2-SE	EGJE-1/2-JC	HFES-1/2-HC	HFES-1/4-SC	HFES-1/2-MC
R485	10	4,880	EGVE-1/2-VC	EGSE-1/2-SE	EGJE-1/2-JC	HFES-1/2-HC	HFES-1/4-SC	HFES-1/2-MC
	12	5,860	EGVE-1/2-VC	EGSE-1/2-SE	EGJE-1/2-JC	HFES-1/2-HC	HFES-1/2-SC	HFES-3/4-MC
	15	7,320	EGVE-3/4-VC	EGSE-1/2-SE	EGJE-1/2-JC	HFES-1/2-HC	HFES-1/2-SC	HFES-3/4-MC
R595	10	6,050	EGVE-1/2-VC	EGSE-1/2-SE	EGJE-1/2-JC	HFES-1/2-HC	HFES-1/2-SC	HFES-3/4-MC
	12	7,260	EGVE-3/4-VC	EGSE-1/2-SE	EGJE-1/2-JC	HFES-1/2-HC	HFES-1/2-SC	HFES-3/4-MC
	15	9,080	EGVE-3/4-VC	EGSE-1-SE	EGJE-1-JC	HFES-1-HC	HFES-1/2-SC	HFES-3/4-MC
R775	10	7,900	EGVE 3/4-VC	EGSE-1/2-SE	EGJE-1/2-JC	HFES-1/2-HC	HFES-1/2-SC	HFES-3/4-MC
	12	9,480	EGVE 3/4-VC	EGSE-1-SE	EGJE-1-JC	HFES-1-HC	HFES-1-SC	HFES-1-MC
	15	11,850	EGVE-1-VC	EGSE-1-SE	EGJE-1-JC	HFES-1-HC	HFES-1-SC	HFES-1-MC
R905	10	8,900	EGVE-3/4-VC	EGSE-1-SE	EGJE-1-JC	HFES-1-HC	HFES-1-SC	HFES-3/4-MC
	12	10,680	EGVE-1-VC	EGSE-1-SE	EGJE-1-JC	HFES-1-HC	HFES-1-SC	HFES-1-MC
	15	13,350	EGVE-1-VC	EGSE-1-SE	EGJE-1-JC	HFES-1-HC	HFES-1-SC	HFES-1-MC
R1025	10	10,200	EGVE-3/4-VC	EGSE-1-SE	EGJE-1-JC	HFES-1-HC	HFES-1-SC	HFES-1-MC
	12	12,240	EGVE-1-VC	EGSE-1-SE	EGJE-1-JC	HFES-1-HC	HFES-1-SC	HFES-1-MC
	15	15,300	EGVE-1 1/2-VC	EGSE-1-SE	EGJE-1-JC	HFES-1 1/2-HC	HFES-1 1/4-SC	HFES-1 1/2-MC
R1305	10	12,800	EGVE-1-VC	EGSE-1-SE	EGJE-1-JC	HFES-1-HC	HFES-1 1/4-SC	HFES-1-MC
	12	15,360	EGVE-1 1/2-VC	EGSE-1-SE	EGJE-1-JC	HFES-1 1/2-HC	HFES-1 1/4-SC	HFES-1 1/2-MC
	15	19,200	EGVE-1 1/2-VC	EGSE-1 1/2-SE	EGJE-1 1/2-JC	HFES-1 1/2-HC	HFES-1 1/2-SC	HFES-1 3/4-MC
R2050	10	20,400	EGVE-1 1/2-VC	EGSE-1 1/2-SE	EGJE-1 1/2-JC	HFES-1 1/2-HC	HFES-1 1/2-SC	HFES-1 3/4-MC
	12	24,480	EGVE-2-VC	EGSE-2-SE	EGJE-1 1/2-JC	HFES-2-HC	HFES-2-SC	HFES-2 1/2-MC
	15	30,600	EGVE-3-VC	EGSE-3-SE	EGJE-2-JC	HFES-2 1/2-HC	HFES-2-SC	HFES-2 1/2-MC

Selections based on 100° Liquid

## **APPLICATION**

High Temp Unit Coolers are designed for use with R12, R22, R134a, R404A, R407A/B/C, R507 or R502 refrigerants. At room temperatures above 34°F and evaporating temps no lower than 27°F the air flowing through the coil will accomplish the defrost. Temperatures of 34°F and below (to -40°F) require positive defrosting. (either Electric or Hot Gas). The coil must not be exposed to any abnormal atmospheric or acidic environments. This may result in corrosion to the cabinet and possible coil failure (leaks). (Consult manufacturer for optional baked on phenolic protective coatings).

## **INSTALLATION**

The installation and start-up of Unit Coolers should only be performed by qualified refrigeration mechanics. This equipment should be installed in accordance with all applicable codes, ordinances and local by-laws.

## **INSPECTION**

Inspect all equipment before unpacking for visible signs of damage or loss. Check shipping list against material received to ensure shipment is complete.

**IMPORTANT:** Remember, you, the consignee, must make any claim necessary against the transportation company. Shipping damage or missing parts, when discovered at the outset, will prevent later unnecessary and costly delays. **If damage or loss during transport is evident, make claim to carrier, as this will be their responsibility, not the manufacturer's.**

Should carton be damaged, but damage to equipment is not obvious, a claim should be filed for "concealed damage" with the carrier.

**IMPORTANT:** The electrical characteristics of the unit should be checked at this time to make sure they correspond to those ordered and to electrical power available at the job site. Save all shipping papers, tags and instruction sheets for reference by installer and owner.

## **LOCATION**

The unit location in the room should be selected to ensure uniform air distribution throughout the entire space to be refrigerated. Make sure that the air is not blown directly out through the opened door and that the product does not obstruct the free circulation of air.

**NOTE: These units drawn air through the fan and discharge air from the coil side.**

When installing the unit adjacent to a wall sufficient clearance (2" (50mm) minimum) must be provided to allow the hinged drain pan to be lowered for servicing the unit. Channel type hangers are provided. Rear hangers are slotted to facilitate installation. See dimensional data.

## **MOUNTING**

Mounting brackets with 7/16" dia holes are provided for flush mounting to the ceiling. For details refer to dimensional data on page 3.

**Ensure that the ceiling is level since the drain pan has been sloped for drainage during the defrost cycle.**

## **DRAIN LINE**

The drain line should be run from the drain connection, sloping at least 4" per foot. A trap outside the room will prevent warm air from entering through the tubing. Connection should be made to proper drainage facilities that comply with local regulations.

**Ensure that the drain pan has sufficient slope for proper drainage (prevention of ice build up/blockage in pan).**

## **PIPING**

Refrigerant line sizes are important and may not be the same size as the coil connections. (depends on the length of run) If in doubt, consult "Recommended refrigerant line sizes" charts. (Engineering Manuals or other recognized sources of information).

## **WIRING**

Wire system in accordance with governing standards and local codes. See data and wiring diagram on page 2, for wiring arrangement. Electrical wiring is to be sized in accordance with minimum ampacity rating.

## **SYSTEM CHECK**

### **Before Start-Up:**

1. All wiring should be in accordance with local codes.
2. Refrigerant lines should be properly sized.
3. Off-cycle defrost systems should include a liquid line solenoid valve.
4. Thorough evacuation and, dehydration has been performed.
5. The suction, discharge, and receiver service valves must be open.
6. The system should include a liquid line drier moisture indicator and suction filter.
7. Pour enough water into the drain pan to allow a good check on drainage and seal the trap.

### **After Start-Up:**

1. Check the compressor oil level to ensure the correct oil charge.
2. Be sure that the expansion valve is properly set to provide the correct amount of superheat.
3. Heavy moisture loads are usually encountered when starting the system for the first time.
4. Check for proper evaporator fan blade rotation.

## **MAINTENANCE**

The unit should be periodically inspected for any dirt or build-up on the fin surface and cleaned if necessary with a soft whisk or brush.

## SERVICE PARTS LIST

MODEL	FAN MOTORS		FAN BLADE	FAN GUARD
	115V S.P.	115V P.S.C.		
R375	170621	1062533	28271	1043043
R485	170621	1062533	28271	1043043
R595	170621	1062533	28270	170512-003
R775	170620	1062541	28272	170512-003
R905	170620	1062541	28269	170512-003
R1025	170620	1062541	28269	170512-003
R1305	170620	1062541	28269	170512-003
R2050	170620	1062541	28269	170512-003

## SERVICE LOG

DATE	COMMENTS

## FINISHED GOODS WARRANTY

The terms and conditions as described below in the General Warranty Policy cover all products manufactured by National Refrigeration.

### GENERAL WARRANTY POLICY

Subject to the terms and conditions hereof, the Company warrants all Products, including Service Parts, manufactured by the Company to be free of defects in material or workmanship, under normal use and application for a period of one (1) year from the original date of installation, or eighteen (18) months from the date of shipment from the Company, whichever occurs first. Any replacement part(s) so supplied will be warranted for the balance of the product's original warranty. The part(s) to be replaced must be made available in exchange for the replacement part(s) and reasonable proof of the original installation date of the product must be presented in order to establish the effective date of the warranty, failing which, the effective date will be based upon the date of manufacture plus thirty (30) days. Any labour, material, refrigerant, transportation, freight or other charges incurred in connection with the performance of this warranty will be the responsibility of the owner at the current rates and prices then in effect. This warranty may be transferred to a subsequent owner of the product.

### THIS WARRANTY DOES NOT COVER

(a) Damages caused by accident, abuse, negligence, misuse, riot, fire, flood, or Acts of God (b) damages caused by operating the product in a corrosive atmosphere (c) damages caused by any unauthorized alteration or repair of the system affecting the product's reliability or performance (d) damages caused by improper matching or application of the product or the product's components (e) damages caused by failing to provide routine and proper maintenance or service to the product (f) expenses incurred for the erecting, disconnecting, or dismantling the product (g) parts used in connection with normal maintenance, such as filters or belts (h) products no longer at the site of the original installation (i) products installed or operated other than in accordance with the printed instructions, with the local installation or building codes and with good trade practices (j) products lost or stolen.

**No one is authorized to change this WARRANTY** or to create for or on behalf of the Company any other obligation or liability in connection with the Product(s). There is no other representation, warranty or condition in any respect, expressed or implied, made by or binding upon the Company other than the above or as provided by provincial or state law and which cannot be limited or excluded by such law, nor will we be liable in any way for incidental, consequential, or special damages however caused.

The provisions of this additional written warranty are in addition to and not a modification of or subtraction from the statutory warranties and other rights and remedies provided by Federal, Provincial or State laws.

## PROJECT INFORMATION

System	
Model Number	Date of Start-Up
Serial Number	Service Contractor
Refrigerant	Phone
Electrical Supply	Fax

**“AS BUILT” SERVICE PARTS LIST**

**Service Parts List  
Label  
To Be Attached  
*HERE***



**NATIONAL REFRIGERATION &  
AIR CONDITIONING CANADA CORP.**



**CANADA**

159 ROY BLVD., BRANTFORD, ONTARIO, CANADA N3R 7K1  
PHONE: 1-800-463-9517 (519)751-0444 FAX (519)753-1140

**USA**

985 WHEELER WAY, LANGHORNE, PA. 19047 USA  
PHONE: 1-888-KEEPUS1 OR 1-888-533-7871